

LEWIS-LHT

Hydraulic Brake (Axial Cylinder)

**USER
MANUAL**



Product Name: LEWIS-LHT (Axial Cylinder)

Product Type: Hydraulic Brake

Instruction Manual:

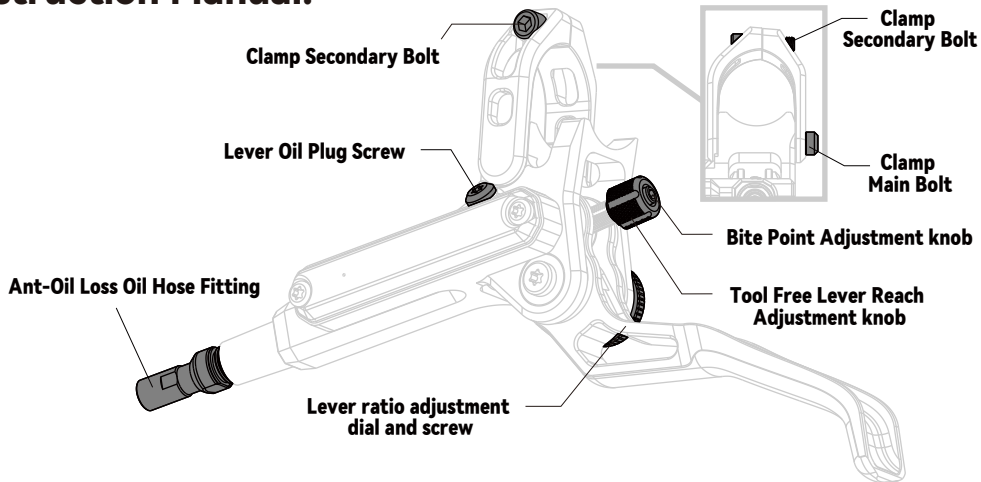



Product Name: LEWIS-LHT (Axial Cylinder)

Product Type: Hydraulic Brake

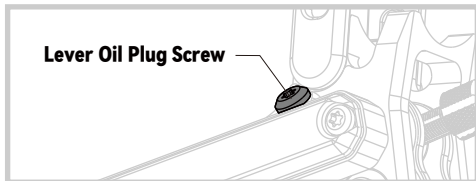

- Remove the **Oil Plug Screw** on the side of the brake lever and use an **M5 bleed fitting** for bleeding. Removing the lever reservoir cover may cause leakage. (**Torque: 3 N·m**)

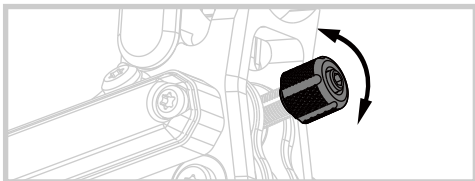

- The **brake lever reach** can be freely adjusted by turning the reach adjustment knob by hand.

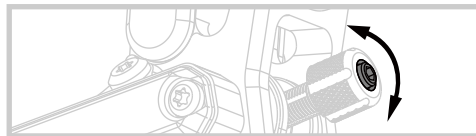

- use a **2mm Allen key** to adjust the bite point of the brake pads.

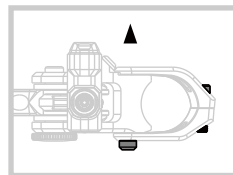
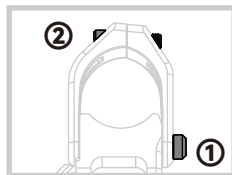

- Use a 3 mm hex wrench to **first tighten the main clamp ring screw (tightening torque: 3 N·m)**, then tighten the secondary clamp ring screw (**tightening torque: 3 N·m**).
- Pay attention to the installation orientation between the clamp ring and the brake lever.

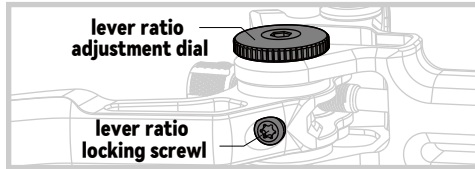

- Loosen the **leverage ratio locking screws** to adjust to your preference using the **leverage ratio adjustment knob**; after adjustment, **tighten the locking screws (1N·m)**.



- The further the lever blade is positioned outward, the softer the feel (the larger the leverage ratio); please adjust according to personal preference.

- LEWIS **Anti-Leak Oil System** can be unscrewed and pulled out without fear of oil spill allowing easy routing for internal cables and easy maintenance.

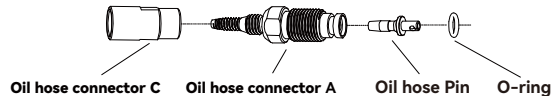
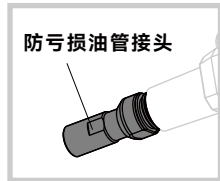

- Anti-leak oil system fittings** : After disassembly, remove both **Oil hose connector A** and **Oil hose connector C** to proceed with the disassembly and assembly of the internal wiring within the frame. After 2-3 re-installation cycles, it is recommended to cut off a section of the hydraulic pipe and utilize the unused portion of the pipe for installation to ensure sealing integrity.



Product Name: LEWIS-LHT (Axial Cylinder)

Product Type: Hydraulic Brake

Screw Retaining Ring (spring clip)

Caliper Oil Plug Screw

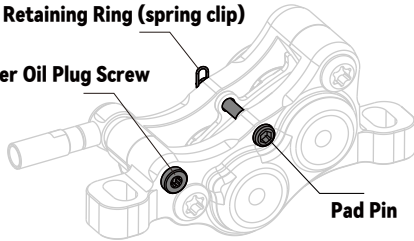

Pad Pin

- During bleeding, always connect the syringe at the caliper end. Avoid operating the syringe from the lever bleed port.
- For **LEWIS-LHT calipers**, the **M6 oil plug screw torque is 2-3 N·m**.
- The installation torque of the LHT brake pad pin must **not exceed 1.5 N·m**, and the screw retaining ring (spring clip) **must be installed**.

- When adjusting the lever reach, please ensure there is sufficient power stroke within the effective braking range.
- Our brakes are filled with mineral oil by default. If necessary, other mineral oils may be used, but please be fully aware of the characteristics of the oil you choose.
- During installation, it is recommended to reset the caliper pistons (clean if dirty) to effectively prevent rotor rub.
- Before mounting the brakes on the bike, please remove the bleeding block inside the caliper, install the supplied brake pads, and check that the **pad retaining screw and spring clip** are properly installed.
- Our brakes come with a **3-year warranty**. If you encounter any issues or uncertainties, please feel free to contact us or a specialized dealer.

Safety Information

- Please read and review all information carefully before use and always follow the procedures stated in the User's Manual.
- Use caution when using a larger disc brake rotor as it provides a higher braking force.
- The disc brake rotor is sharp enough to inflict severe injury to your fingers if they come in contact with the rotating rotor. The brake may not work properly if the brake lining is contaminated with oil or grease.
- Stop using the brake if the disc brake rotor becomes worn down to thickness limit.
- If fluid leaks occur, immediately stop using the brakes and consult a dealer or an agency.
- Vapor lock may occur if the brakes are applied continuously.
- The wheel may lock if the front brake is applied too strongly.
- The braking distance will be longer in humid weather.
- This brake is designed for downhill or free riding, with higher braking force compared to other brakes. If not familiar with this brake, accidents may occur that can cause serious injury or even death.
- If mineral oil comes into contact with eyes and skin, it may result in irritation. If in contact with eyes, rinse with water and receive immediate medical assistance. Inhalation of vapors or mineral oil mist may cause nausea.
- As the brake disc wears out, the space in the oil circuit increases. Please pay attention to replenishing the oil.
- DO NOT dismantle or modify this product.
- Please keep the User's Manual for future reference.

Safety Information

Check the following before riding the bicycle.

- Is the brake oil leaking?
- Do the front and rear brakes work correctly?
- Does each brake lining have a thickness of 0.5 mm or more?
- Is the disc brake rotor cracked or deformed?
- Are there any abnormal noises?
- Is the brake lever secure?
- Is the brake lever peeling or cracking?

If you notice any potential problem, please contact the place of purchase or a bicycle dealer.

QC PASS



LEWIS

**ALL FOR
CYCLING
EXPERIENCE**

POWERED BY:



Website: www.lewisbike.com

